

Dimensional Layout:

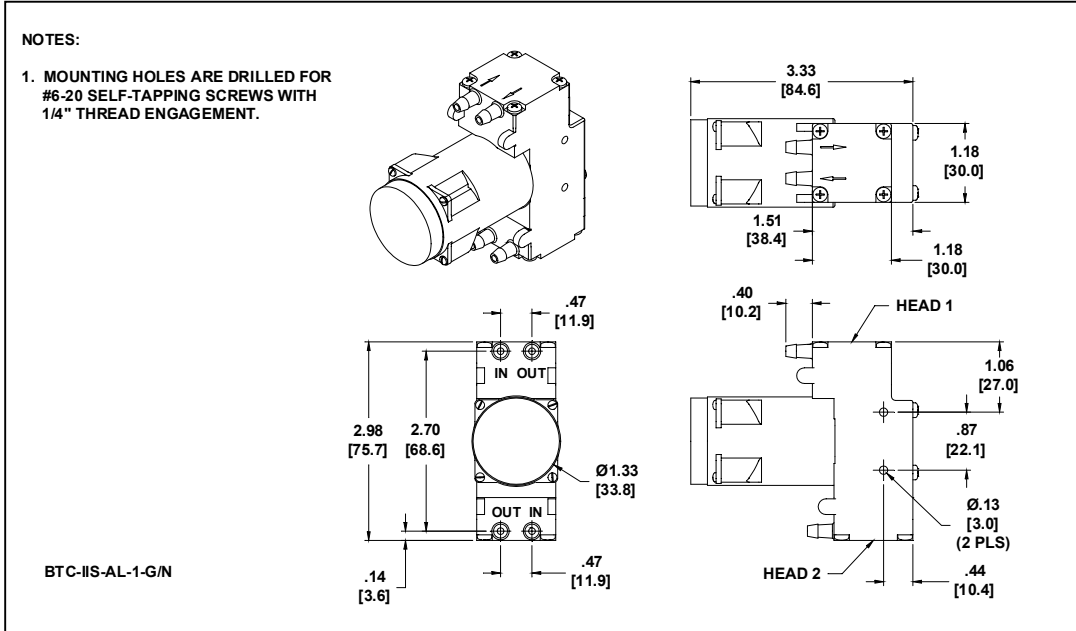

Specifications:

- | | | | | | | |
|-----------------------------|------------------------------|---------------------|-----------------------|-----------------------------------|--|----------------------------------|
| 1. Wetted Materials: | Pump Head: | Vectra [LCP] | 3. Electrical: | Motor: | Brushless, Dual Bearing | |
| | Retainer Washer: | 2024 Alum [750/750] | | Operating Voltage: | 12 VDC | |
| | Retainer Screw: | 316 Stainless | | In-rush Current: | 5 x Operating Current for up to 50 ms | |
| | Valves: | AEPDM [Q80/Q80] | | Recommended Fusing: | Slow Blow @ 2 x Operating Current | |
| | Diaphragm: | AEPDM [C80/C80] | | Temperature Range: | 5 - 50° C | |
| | Gasket: | EPDM [65] | Free Flow RPM: | 3600 | | |
| 2. Performance: | | <u>Continuous</u> | <u>Maximum</u> | 4. Other: | Eccentric: | A900/A900 |
| | - Vacuum in Hg: [Air] | Per Head: | 8.0 | | 20.0 | 5. Operating Limitations: |
| | | | | 6. Recommended Filtration: | 40 Micron media w/ minimum surface area of .59 square inch | |

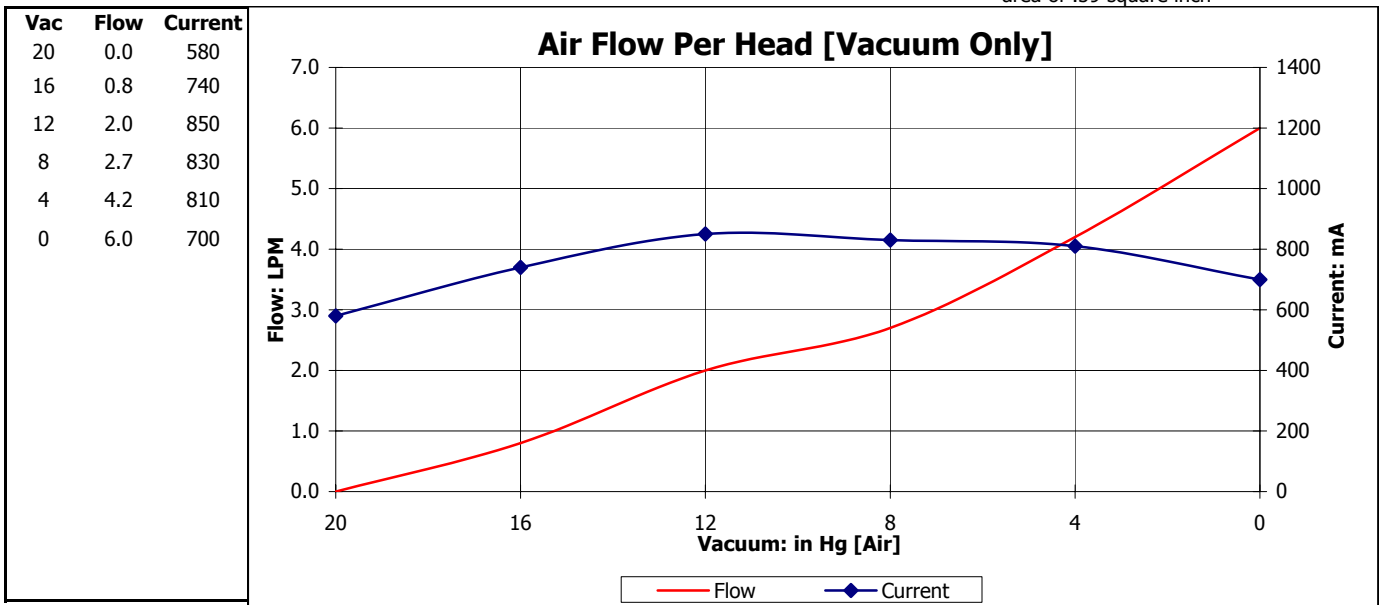

The above graph denotes nominal performance at 800' above sea level at 24 degrees C and at the specified voltage.

ST